

# PROPORTIONAL OUTPUT THUMBWHEEL

**HTWS**  
SUBMINIATURE  
THUMBWHEEL

## SUBMINIATURE PROPORTIONAL OUTPUT THUMBWHEEL WITH OPTIONAL SEAT BOOT

The HTWS Hall Effect Proportional Output Thumbwheel is a smaller version of OTTO's HTW and HTWM. It is a spring return-to-center, single axis thumbwheel that provides a linear change in voltage output corresponding to actuator movement in either direction from center. Its smaller size makes it a perfect choice for use in grips or panels where space is limited. The HTWS is available with eight output options, including increasing and decreasing voltage output from the center position to the full travel position and single or dual (redundant) outputs.

The HTWS snaps into a 0.895" x 0.420" panel opening. Electronics are sealed to IP68S, and the optional sealing boot is offered for above panel mechanical protection against dust, sand, and water ingress. The HTWS offers a three million cycle rotational life, operate force options and excellent EMI /RFI immunity. It is available with flying wire leads or pin connection.

### Features:

- 8 output options
- Spring return-to-center single axis actuator
- Installs into 0.895" x 0.420" panel opening
- Integrated snap-in retaining feature
- Sealing boot option
- 3 million cycle rotational life
- Electronics sealed to IP68S
- Excellent EMI/RFI immunity
- Flow through design
- RoHS compliant



Standard Characteristics/Ratings:				
<b>ELECTRICAL RATINGS: Rated at 5V @ 25°C Load = 1mA (4.7KΩ)</b>				
Electrical	Units	Min	Typ	Max
Supply Voltage	VDC	4.5	5.0	5.5
Output Voltage	VDC	-25	N/A	+25
Tolerance at Center	@ 5V V <sub>cc</sub>			
Output Voltage	VDC	-25	N/A	+25
Tolerance Full Travel	@ 5V V <sub>cc</sub>			
Supply Current Per Sensor	mA	N/A	N/A	20
B=0, V <sub>cc</sub> =5V, I <sub>out</sub> =0				
<b>MECHANICAL:</b>				
<b>Mechanical Life:</b>	3,000,000 full forward to full back (button styles 1, 2) 1,000,000 full forward to full back (button style 3)			
<b>Max Allowable Radial Load:</b>	15.0 lbs. (button styles 1, 2); 10.0 lbs (button style 3)			
<b>ENVIRONMENTAL:</b>				
<b>Operating Temp Range:</b>	-40°C to +85°C			
<b>Humidity:</b>	96% RH, 70°C, 96 hours			
<b>Vibration:</b>	Per MIL-810F minimum integrity			
<b>Electronics Enclosure:</b>	IP58S (button styles 1, 2) IP68S (button style 3)			
<b>Mechanical Enclosure:</b>	Unsealed (button styles 1, 2)			
<b>Mechanical Enclosure:</b>	IP68S (button style 3) (above panel)			
<b>Mechanical Enclosure:</b>	Unsealed (button style 3) (below panel)			
<b>RFI:</b>	ISO 11452-2 & ISO 11452-4 (Single Output) SAE J1113-21 & SAE J1113-22 (Dual Output)			
<b>EMI:</b>	ISO 11452-8 (Single Output) SAE J1113-22 (Dual Output)			
<b>ESD (Powered &amp; Un-Powered):</b>	ISO 10605 (Single Output) SAE J1113-13 (Dual Output)			
<b>MATERIALS:</b>				
<b>Button Top:</b>	Thermoplastic			
<b>Bezel:</b>	Thermoplastic			
<b>Boot:</b>	Silicone Rubber, Black			

### HTWS PROPORTIONAL THUMBWHEEL PART NUMBER CODE

HTWS	-	X	X**	X	X	X	X****	X*****
Travel	Output 1	Output 2	Operate Force	Button Style	Termination	Bezel Color	Button Color	
1. +/-30°	A. 2.5 +/- 2.0VDC	NONE	1. 5 oz. typ.	1. Knurled Wheel*	A. Wire Leads, 22	1. Red	1. Red	
2. +/-45°*	B. 2.5 +/- 2.0VDC	2.5 +/- 2.0VDC	2. 8.5 oz. typ.	2. Paddle Wheel	AWG UL 1569	2. Black	2. Black	
	C. 2.5 +/- 2.0VDC	2.5 +/- 2.0VDC	3. 12 oz. typ.	3. Paddle Wheel with Seal Boot***	(Single Output Only)		3. Orange	
	D. 2.5 +/- 1.5VDC	NONE			B. Wire Leads, 22		4. Yellow	
	E. 2.5 +/- 1.5VDC	2.5 +/- 1.5VDC			AWG UL 1569,		5. Green	
	F. 2.5 +/- 1.5VDC	2.5 +/- 1.5VDC			(Dual Output Only)		6. Blue	
	G. 1.0 - 4.0VDC	1.0 - 4.0VDC					7. Violet	
	H. 0.5 - 4.5VDC	0.5 - 4.5VDC					8. Gray	
							9. White	

\* Not available with Operate Force selection "3"

\*\* Outputs are from the center position to the full travel position in each direction. Options "A" "B" "C" "D" "E" "F" provide increasing voltage in direction 1 and decreasing voltage in direction 2 from a single output. Option "G" and "H" provide increasing voltages in both directions from two separate outputs. Option "B" and "E" provide redundant output 2 which duplicates output 1. Option "C" and "F" provide redundant output 2 which is inverse of output 1.

\*\*\* Available with Operate Force selection "3" only

\*\*\*\* Contact Factory for additional bezel color choices.

\*\*\*\*\* Minimums may apply to colors other than red and black.

SUBMINIATURE PROPORTIONAL OUTPUT THUMBWHEEL WITH OPTIONAL SEAT BOOT

## HTWS Paddle Wheel Style Shown

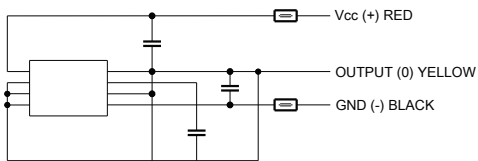
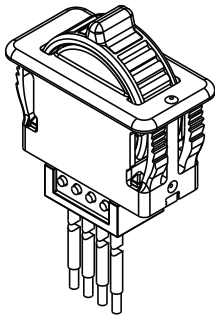

SINGLE OUTPUT SCHEMATIC

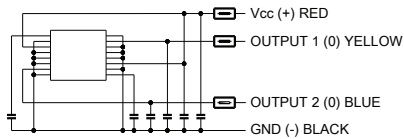

DUAL OUTPUT  
COMMON POWER & GROUND  
SCHEMATIC

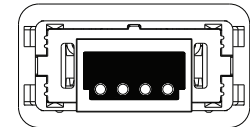
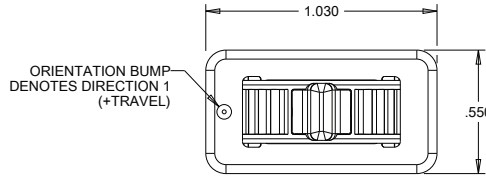
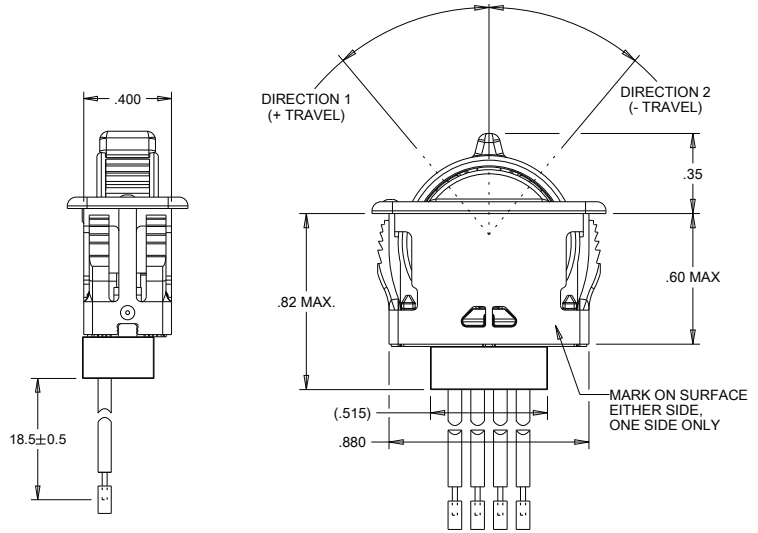

NOT ALL WIRES ARE PRESENT  
IN ALL OUTPUT CONFIGURATIONS

**MOUNTING:**  
RECOMMENDED PANEL THICKNESS: 0.150 OPTIMUM THICKNESS

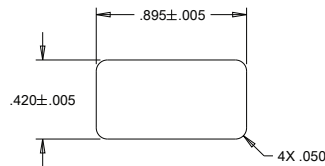

## HTWS Paddle Wheel with Boot Style Shown

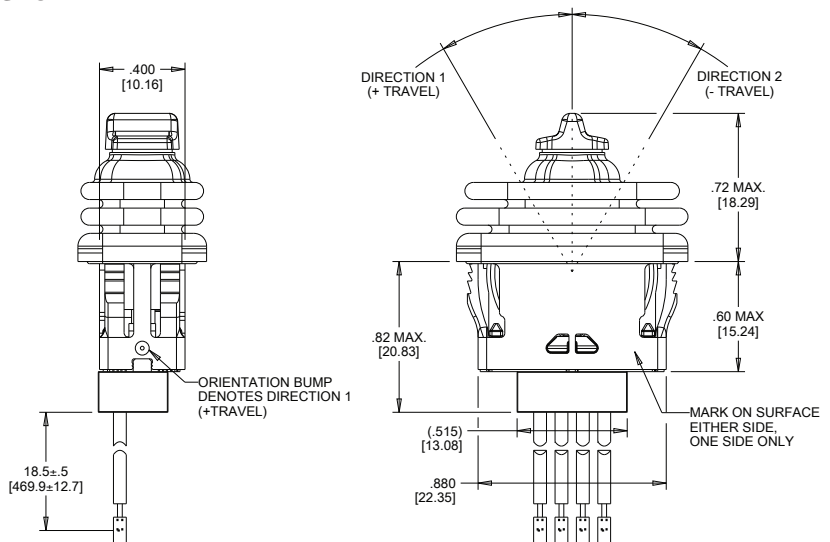
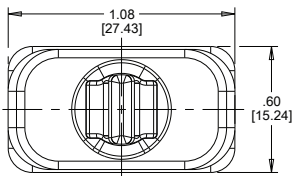
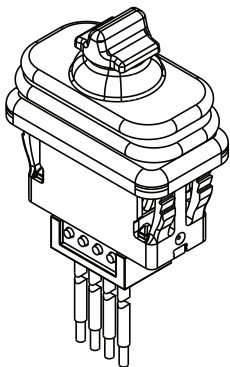

# PROPORTIONAL OUTPUT THUMBWHEEL

## SUBMINIATURE PROPORTIONAL OUTPUT THUMBWHEEL WITH OPTIONAL SEAT BOOT

**OPTION A**

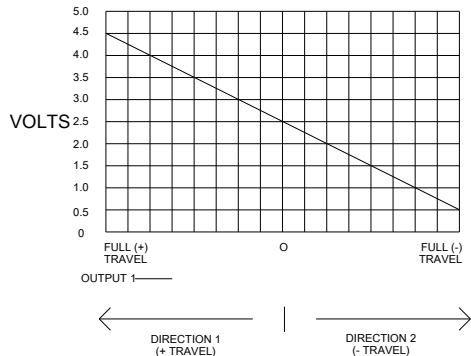

**OPTION B**

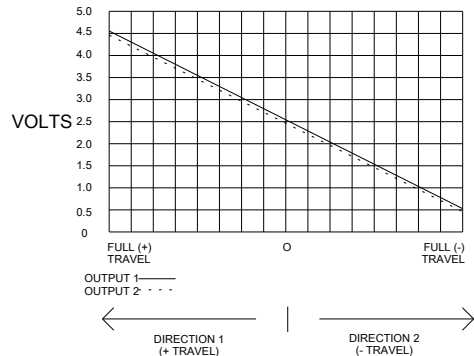

**OPTION C**

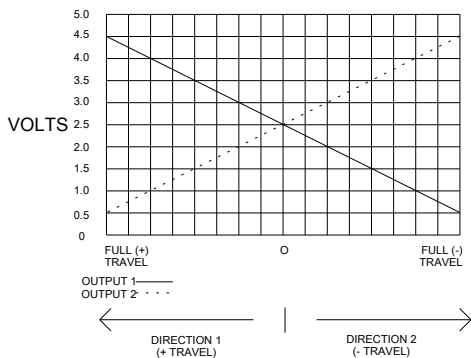

**OPTION D**

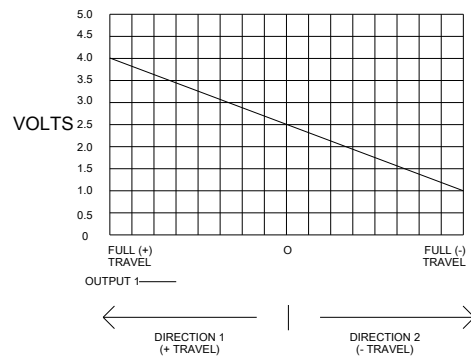

**OPTION E**

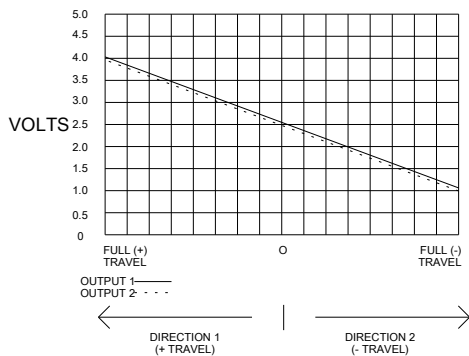

**OPTION F**

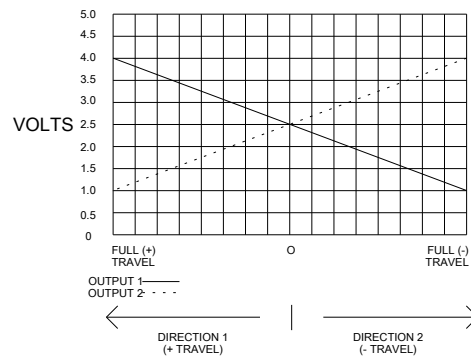

**OPTION G**

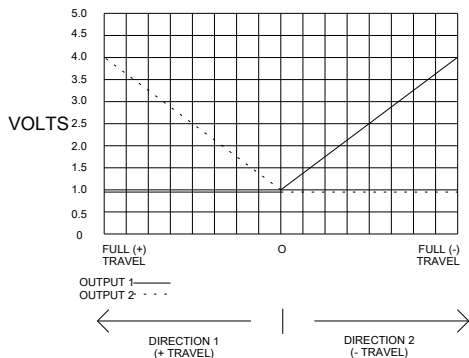

**OPTION H**

