



**HEAVY
DUTY
CATALOG
2020**



Extremely robust

The Fenac Heavy Duty Encoders are designed to withstand the toughest conditions. These encoders have extra-strong, impact-resistant stainless steel or aluminum housings.



Extreme Environment

The harsh environment of steel mills, wing-turbines, mining, off-shore facilities or gantry cranes demands strong encoders. Reliable long-term operation is ensured by a mechanical design tailor-made to these applications. Heavy Duty series encoders provides the perfect match for your application.

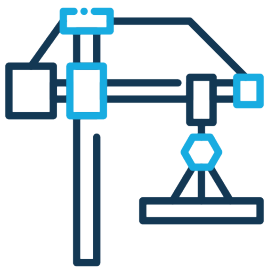

Cranes

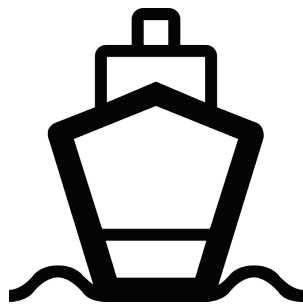

Marine
Vessels

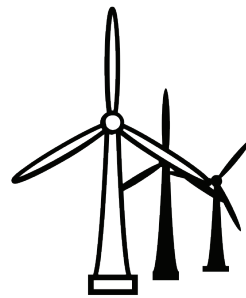

Wind
Turbines

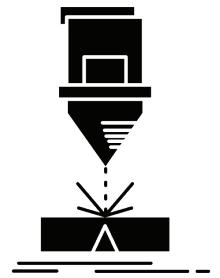

Iron - Steel
Industry

Safe & precise

- » Quick installation, less downtime
- » Reliable sensing technology
- » Safe at extreme temperatures
- » Protected against bearing damage

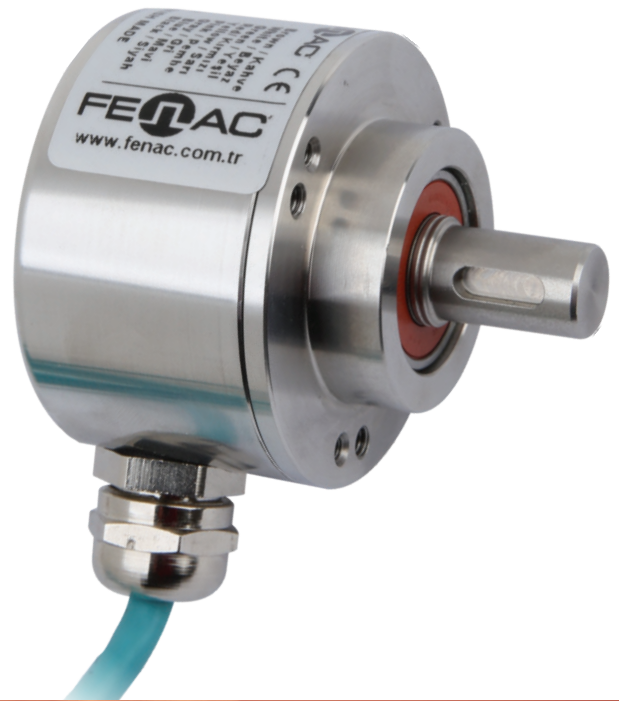

Encoder combined with integrated speed switch

- » Mechanical speed monitoring by the centrifugal principle
- » Switching speed pre-selectable as default
- » Tried and tested, energy self-sufficient technology



FNC 50 HDD Series

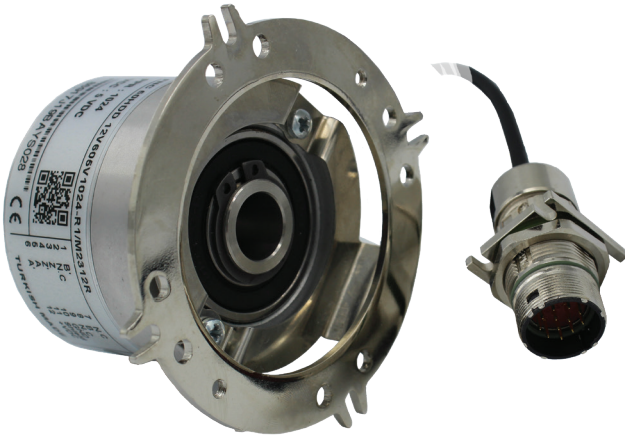

Features

- » Industry 50 mm standard size, through hollow shaft
- » Robust mechanical and electrical construction
- » Up to 65.536 ppr max.
- » <300 kHz frequency

Technical Data

Consumption w/o load	<60 mA (24 VDC)
Pulses per revolution	1...65.536
Reference signal	Zero pulse, width 90°, 180°, 360° optional
Output signal	90° shifted A and B, Z+ inverted
Operating speed	<10.000 rpm
Weight Approx.	150 g

**Direct replacement to RHI 593
(LEINE LINDE)**

Mechanical Dimensions

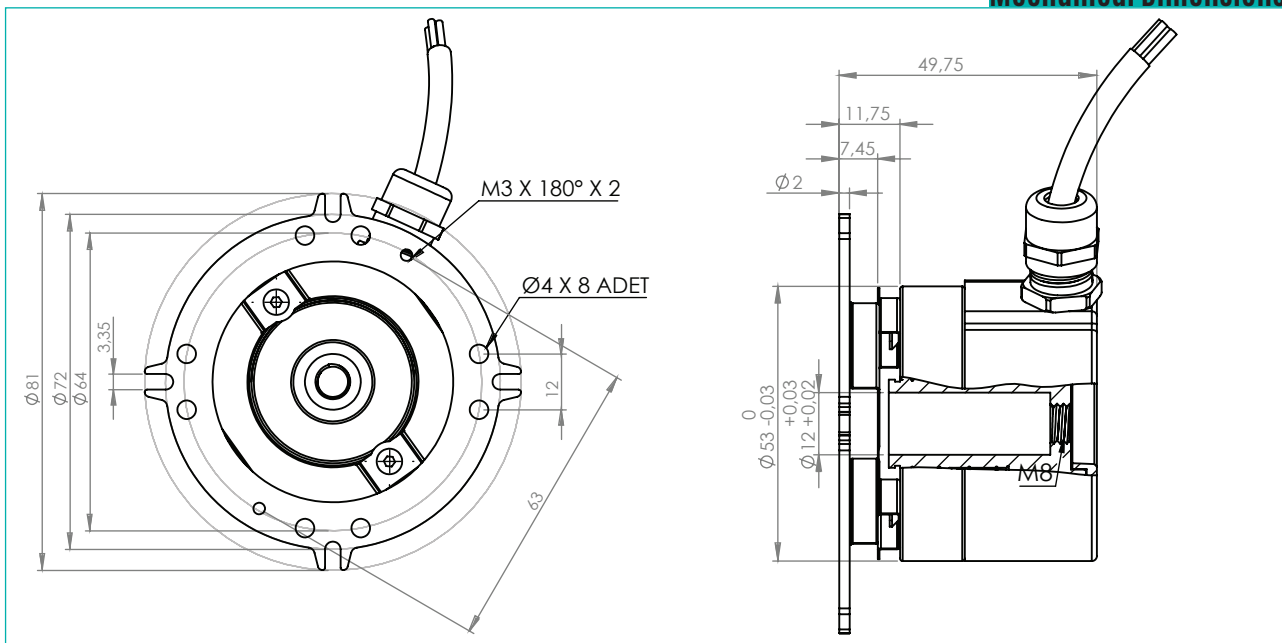

FNC 58B SS Series



Features

- » Robust compact housing
- » Two bearings with large distance
- » High shaft load up to 400N
- » Highest operating speed 10.000 rpm
- » Terminal box, M23 conenctor, cable options

Technical Data

Consumption w/o load	<60 mA (24 VDC)
Pulses per revolution	1...65.536
Reference signal	Zero pulse, width 90°, 180°, 360° optional
Output signal	90° shifted A and B, Z+ inverted
Operating speed	<10.000 rpm
Connection	Flange connector M23, 12-pin
Weight Approx.	500 g

Mechanical Dimensions

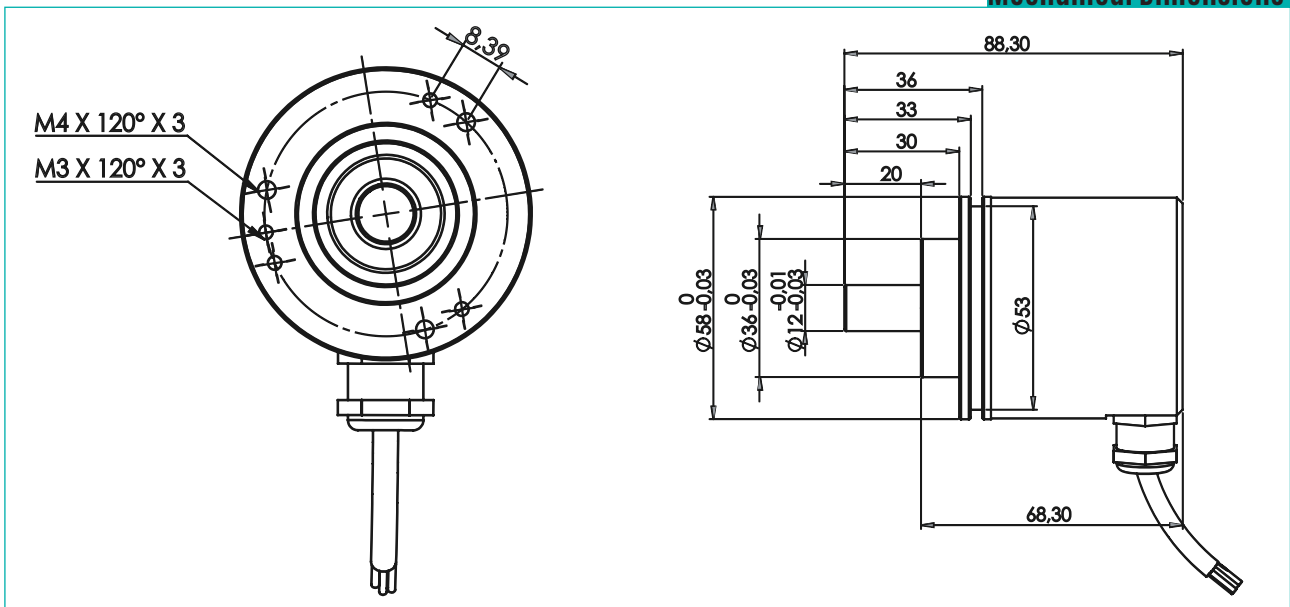

FNC FHD H75 Series

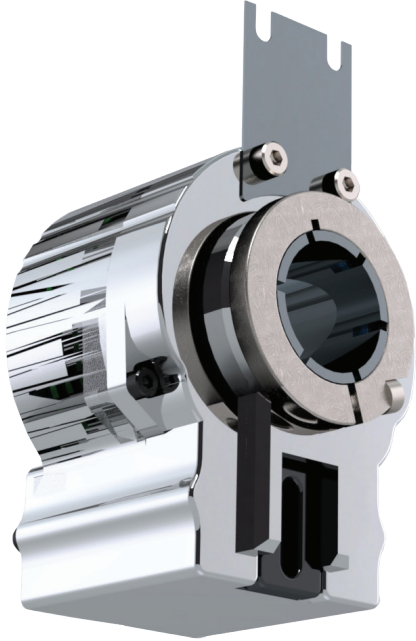

Features

- » Robust compact housing
- » Two bearings with large distance
- » High shaft load up to 400N
- » Highest operating speed 10.000 rpm
- » Terminal box, M23 connector, cable options

Technical Data

Consumption w/o load	<100 mA
Pulses per revolution	1000...10.000
Output Stages	Push-pull / TTL /RS422
Reference signal	Zero Pulse, width 90°
Operating speed	<10.000 rpm
Connection	Terminal box Flange connector M23, 12-pin Cable 1m
Weight Approx.	1,2 kg

Mechanical Dimensions

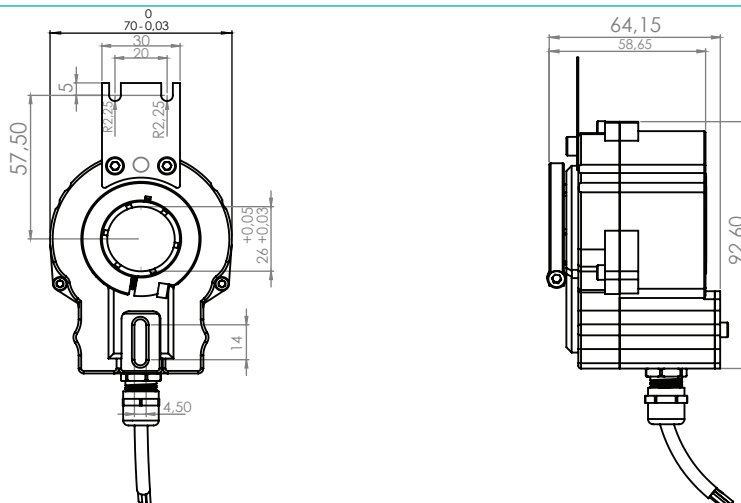

FNC FHD H100 Series



Features

- » Robust compact housing
- » Two bearings with large distance
- » High shaft load up to 400N
- » Highest operating speed 10.000 rpm
- » Terminal box, M23 conector, cable options

Technical Data

Consumption w/o load	<100 mA
Pulses per revolution	1000...10.000
Output Stages	Push-pull / TTL /RS422
Reference signal	Zero Pulse, width 90°
Operating speed	<10.000 rpm
Connection	Terminal box Flange connector M23, 12-pin Cable 1 m
Weight Approx.	1,1 kg

**Direct replacement to 861007455-1024
(LEINE LINDE)**

Mechanical Dimensions

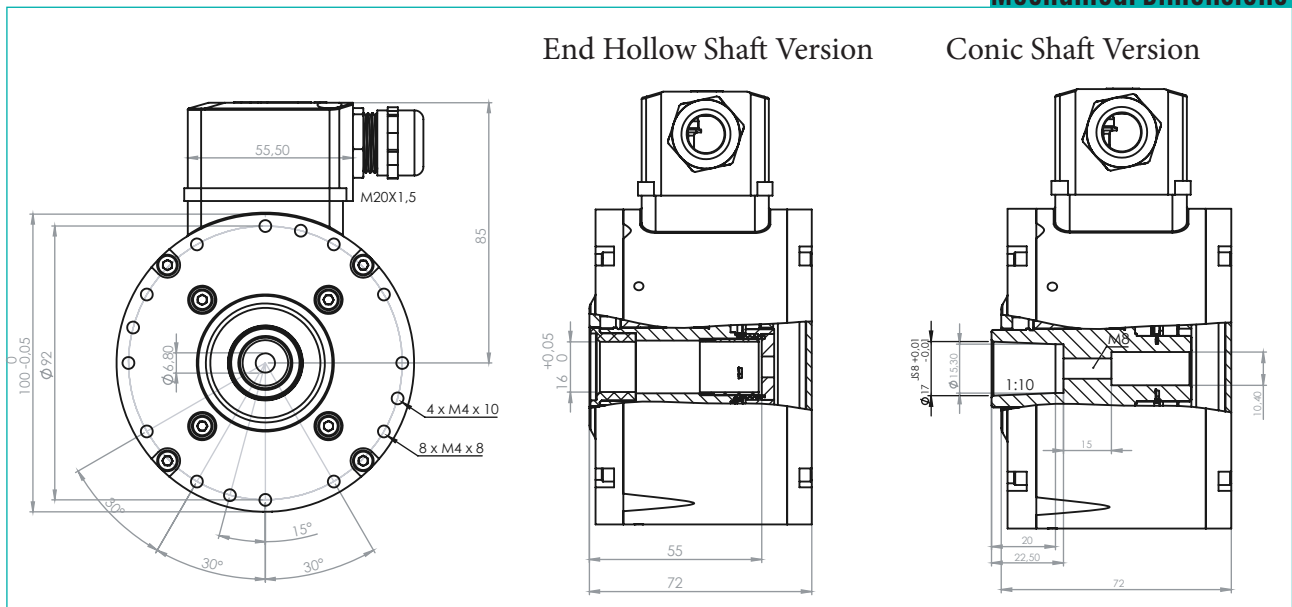

FNC FHD S115 Series



Features

- » Robust compact housing
- » Two bearings with large distance
- » High shaft load up to 300N
- » Highest operating speed 10.000 rpm
- » Terminal box, M23 conenctor, cable options

Technical Data

Consumption w/o load	<100 mA
Pulses per revolution	1000...10.000
Output Stages	Push-pull / TTL /RS422
Reference signal	Zero Pulse, width 90°
Operating speed	<10.000 rpm
Connection	Terminal box Flange connector M23, 12-pin Cable 1m
Weight Approx.	1,2 kg

Mechanical Dimensions

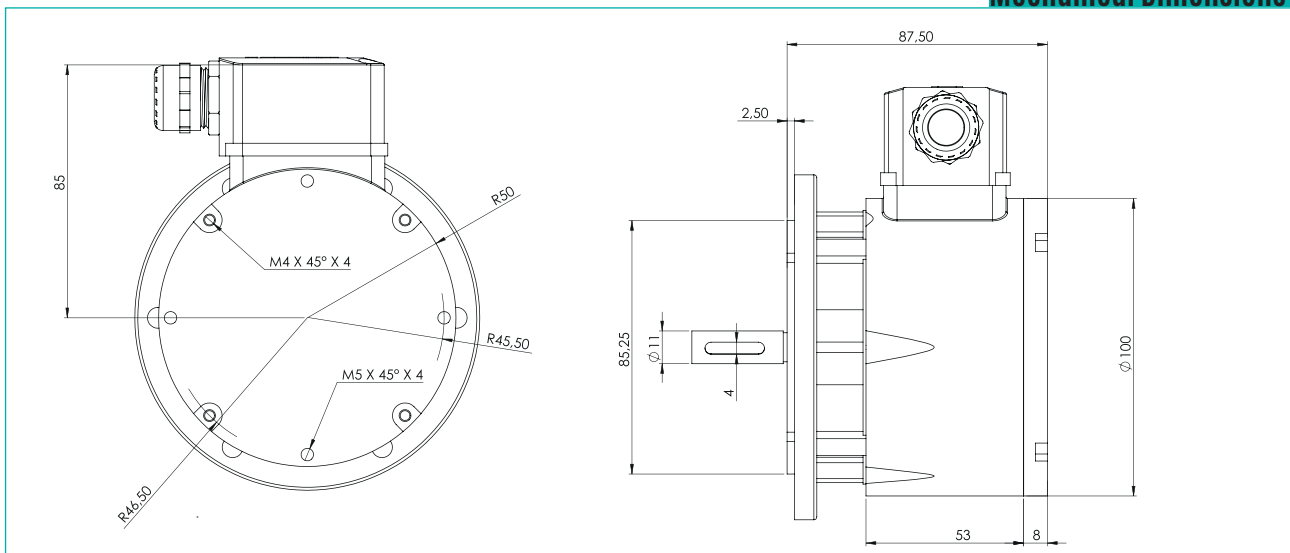

FNC 115S Series

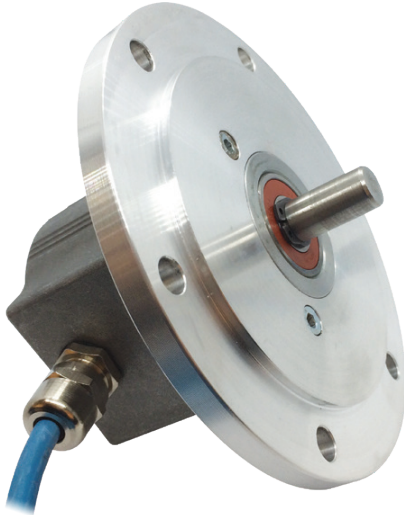

Features

- » Digital tachogenerator with robust tacho flange
- » Industry 115 mm standard size
- » High noise immunity against frequency
- » Protection up to IP67
- » Up to 65.536 ppr max.
- » <300 kHz frequency

Technical Data

Consumption w/o load	<60 mA (24 VDC)
Pulses per revolution	1...65.536
Reference signal	Zero pulse, width 90°, 180°, 360° optional
Output signal	90° shifted A and B, Z+ inverted
Operating speed	<10.000 rpm
Weight Approx.	500 g

Mechanical Dimensions

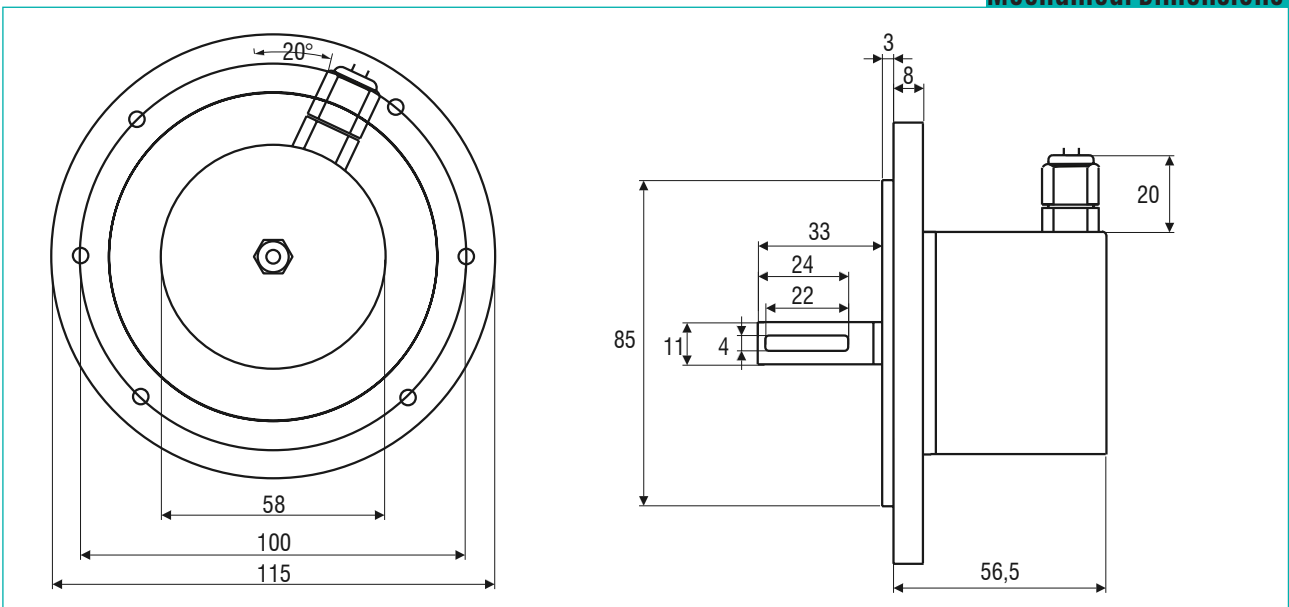

Product Details

1

Terminal box rotatable 180°

2

1st PPR output and 2nd PPR output are totally redundant.

3

Optical and electronic side are independent



Easy, quick and safe connection



Protection up to IP67



High temperatures



Suitable for Heavy Environment



Robust design



Cold climate



Easy electrical connection

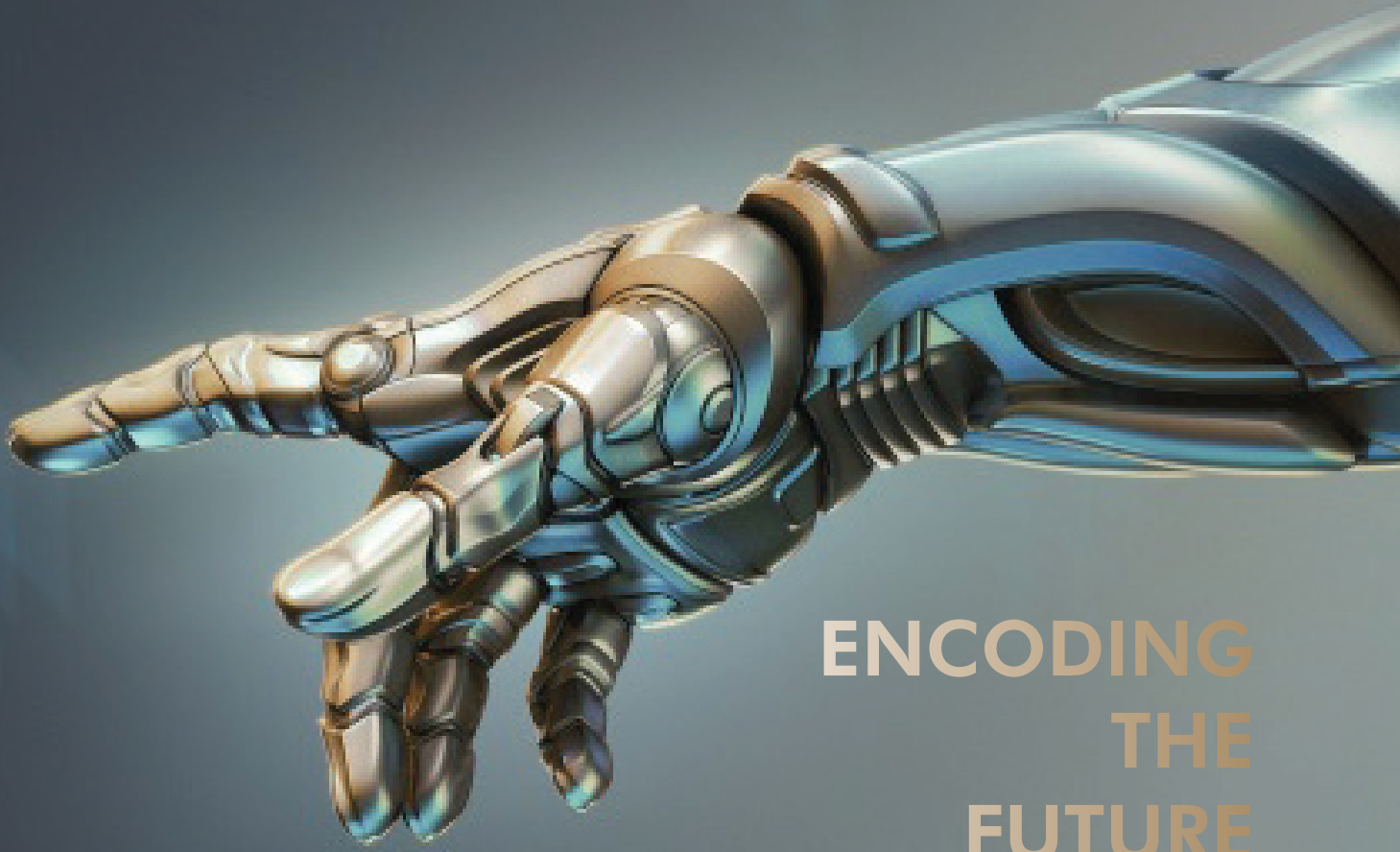

ENCODING
THE
FUTURE



FENAC MÜHENDİSLİK SAN. TİC. LTD. ŞTİ.
Ferhatpaşa Mah. 35.Sk. No:20 Ataşehir 34888 İstanbul-Turkey
Tel/Phone : +90 216 232 27 00 Faks/Fax : +90 216 661 10 22

www.fenac.com.tr
info@fenac.com.tr

