

Series

84

*E-Stops and Stop Switches.*

[www.eao.com](http://www.eao.com)

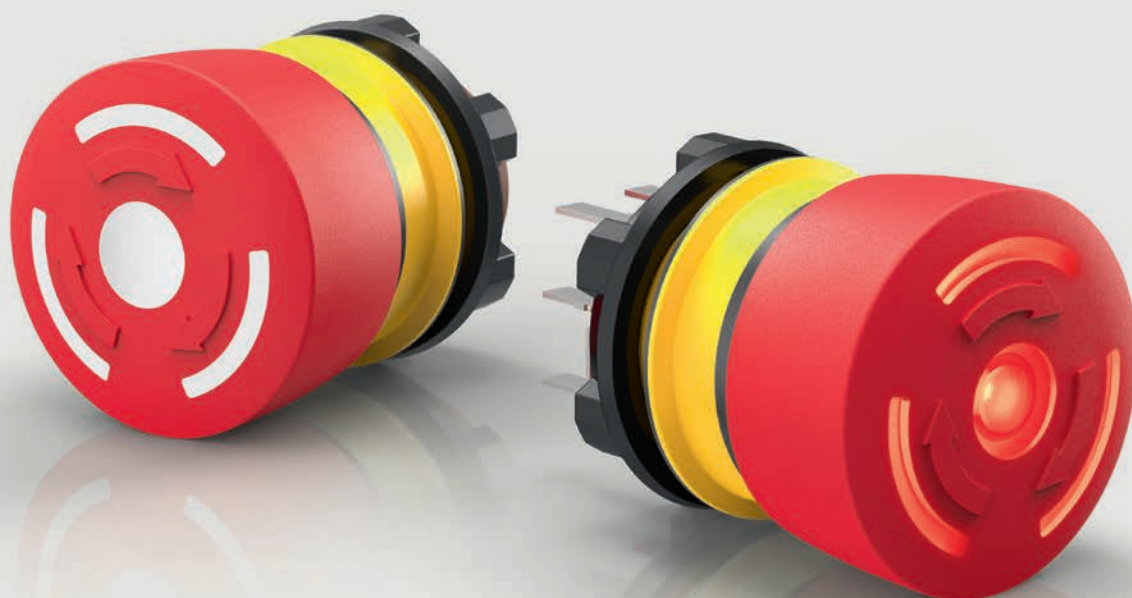

# Series 84

## *E-Stops and Stop Switches.*

**EAO offers intuitive, reliable and robust safety switches for the machinery industry: *The Series 84 emergency stop and stop switches have a compact, attractive design with a very low back panel depth.***

EAO, the expert partner for innovative, intuitive and reliable Human Machine Interfaces (HMIs), offers with the Series 84 emergency stop (E-Stop) and stop switches the most important safety control elements for machinery and industrial automation equipment with very low back panel depth (13.5 mm with cable connection) and an attractive design.

The intuitive Series 84 emergency stop and stop switches are particularly suitable for handheld and compact control units, where besides highest safety requirements also a very low back panel depth is critical and where the front of panel height as well as ergonomic styling are important design factors.

Installed directly on the machine or in a handheld control unit, these switches reliably protect humans from injury and machines from damage.

The compact design of the Series 84 emergency stop and stop switches makes it ideal for use in industrial machinery, process automation, and robotics as well as lifting, moving and material handling equipment.

The robust mono-block construction and a choice of terminals allow easy mounting in modern safety control systems and help to meet the needs of industry standards for fail-safe actuation.

The actuation status of the switch is visible thanks to the green or black indication ring that is noticeable until actuated. LED illumination gives additional status information and can also be used to locate the switch, even in low ambient light conditions.

### Typical applications

- Industrial or process automation equipment
- Machinery, in particular for handheld control units
- Robotics
- Material handling and lifting platforms
- Medical devices

### Product range

All E-Stops and stop switches are available either with solder/plug-in terminal or flat ribbon cable (300 mm).

The switching element is available with a double break contact with either

- a normally closed contact (NC)
- two normally closed contacts (NC)
- a normally closed contact (NC) and a normally open contact (NO)

The normally closed contacts are force-operated according to EN IEC 60947-5-1 and can switch voltages and currents from 1 VAC/DC / 1 mA (1W) thanks to highly reliable, gold-plated silver contacts.

### Mechanical characteristics

- Mounting cut-out 22.3 mm
- Operation force 17 N ± 4 N

### Mechanical life

EAO tested: more than 250 000 cycles of operation

### Illumination

New and improved LED illumination results in greater visibility even in ambient light conditions. The integrated red LED is equipped with reverse polarity protection and a constant current source, all while maintaining a constant brightness at operating voltages from 5VDC to 30VDC.

### Switching capacity

Alternating voltage with gold-plated silver contacts  
Utilisation category AC-15, according to EN IEC 60947-5-1

Voltage	120 VAC	240 VAC
Current	3 A	1.5 A

Direct voltage with silver contact (gold-plated)  
Utilisation category AC-13, according to EN IEC 60947-5-1 (inductive)

Voltage	12 VDC	24 VDC	60 VDC	125 VDC	250 VDC
Current – version with solder/plug-in terminal	5 A	4 A	1.7 A	0.55 A	0.27 A
Current – cable version	3 A	3 A	1.70 A	0.55 A	0.27 A

## Advantages.

- Robust mono-block with a foolproof and fail-safe design
- Very low back panel depth
- Attractive, modern design and protection IP65/67
- Reliable and long service life
- Clearly visible illumination

### Recommended operating data

	Minimum	Maximum
Voltage	1 VAC/DC	250 VAC/DC
Current	1 mA	0.27 mA
Power	1 Watt	67.5 Watt

### Degree of protections

- IP65/67 front side
- IP20 rear side
- IP40 rear side (cable version)

### Temperatures

- Storage temperature  
-25 °C to +85 °C
- Operating temperature  
-25 °C to +65 °C

### Climate resistance

- Humid heat, cyclical  
96 hours, +25 °C/97%, +55 °C/93% relative humidity
- Humid heat, constant  
56 days, +40 °C/93% relative humidity
- Dry heat, 96 hours, +70 °C
- Cold, 96 hours, -40 °C
- Salt spray, 96 hours,  
+35 °C (in NaCl solution)

### Standards and directives

- Approvals
  - EN 60947-5-1/EN 60947-5-5
  - DIN EN ISO 13850
  - EN IEC 60204
  - UL Cat NISD 508 (pending)
  - CCC (pending)

- Conformities
  - CE

### Mounting

The mounting of the emergency stop and stop switch is performed on the front panel side with the aid of the fixing nut. The anti-rotation device is secured with a cam via its hole shape. The electrical connection takes place using plug-in terminal pairs, which can also be soldered on.

### Accessories

The direct mounting onto the printed circuit board can take place by means of an adapter (part no. 84-920). Further accessories such as mounting tools, protective shrouds or marking plates can be found in the EAO product catalogue.

Further information and the Online Product Configurator are available under [www.eao.com/84-e-stop](http://www.eao.com/84-e-stop)

### Dimensions

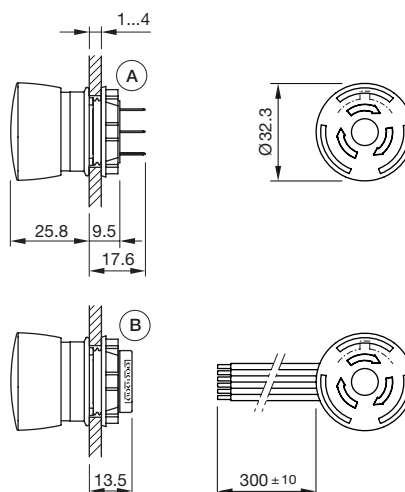

### Mounting cut-outs

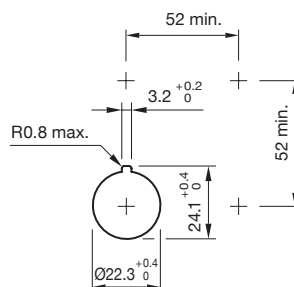

All dimensions in mm.

# EAO Contact.

## *Your centre of excellence.*

### Headquarters

EAO Holding AG  
Tannwaldstrasse 88  
CH-4600 Olten  
Telephone +41 62 286 92 00  
info@eao.com

### Manufacturing Companies

**Switzerland**  
EAO AG  
Tannwaldstrasse 88  
CH-4600 Olten  
Telephone +41 62 286 91 11  
info@eao.com

EAO Systems AG  
Tannwaldstrasse 88  
CH-4600 Olten  
Telephone +41 62 286 91 11  
sales.esy@eao.com

**China**  
EAO (Guangzhou) Ltd.  
3/F, Block G4, South China  
New Materials Innovation Park  
31 Kefeng Road  
Guangzhou Science City  
CN-Guangzhou, PRC  
Telephone +86 20 3229 0390  
sales.ecn@eao.com

**Germany**  
EAO Automotive GmbH & Co. KG  
Richard-Wagner-Straße 3  
DE-08209 Auerbach/Vogtland  
Telephone +49 3744 8264 0  
sales.esa@eao.com

**North America**  
EAO Corporation  
One Parrott Drive  
Shelton  
US-CT 06484  
Telephone +1 203 951 4600  
sales.eus@eao.com

### Sales Companies

**China**  
EAO (Guangzhou) Ltd.  
3/F, Block G4, South China  
New Materials Innovation Park  
31 Kefeng Road  
Guangzhou Science City  
CN-Guangzhou, PRC  
Telephone +86 20 3229 0390  
sales.ecn@eao.com

EAO (Shanghai) Office  
Rm. 403, Block 5#  
CIFI Century Square, Lane 28  
NO. 21, Danba Road  
Putuo District  
CN-Shanghai, PRC  
Telephone +86 21 6095 0717  
sales.ecn@eao.com

**France**  
EAO France SAS  
5, rue Henri François  
FR-77330 Ozoir-la-Ferrière  
Telephone +33 1 64 43 37 37  
sales.efr@eao.com

**Germany, Austria,  
Poland, Czech Republic**  
EAO GmbH  
Langenberger Straße 570  
DE-45277 Essen  
Telephone +49 201 8587 0  
sales.ede@eao.com

**Hong Kong (Asia Pacific)**  
EAO (Far East) Ltd.  
Unit A1, 1/F, Block A  
Tin On Industrial Building  
777 Cheung Sha Wan Road  
Lai Chi Kok, Kln  
HK-Hong Kong  
Telephone +852 27 86 91 41  
sales.ehk@eao.com

**Italy**  
EAO Italia S.r.l.  
Centro Direzionale Summit –  
Palazzo D1  
Via Brescia 28  
IT-20063 Cernusco sul Naviglio (MI)  
Telephone +39 02 92 471934  
sales.eit@eao.com

**Japan**  
EAO Japan Co. Ltd.  
Net 1 Mita Bldg. 3F  
3-1-4 Mita Minato-ku  
JP-Tokyo 108-0073  
Telephone +81 3 5444 5411  
sales.ejp@eao.com

**Netherlands, Belgium**  
EAO Benelux B.V.  
Kamerlingh Onnesweg 46  
NL-3316 GL Dordrecht  
Telephone +31 78 653 17 00  
sales.enl@eao.com

**North America**  
EAO Corporation  
One Parrott Drive  
Shelton  
US-CT 06484  
Telephone +1 203 951 4600  
sales.eus@eao.com

**Switzerland**  
EAO Schweiz AG  
Tannwaldstrasse 86  
CH-4600 Olten  
Telephone +41 62 286 95 00  
sales.ech@eao.com

**United Kingdom, Finland,  
Ireland, Norway, Sweden**  
EAO Ltd.  
Highland House  
Albert Drive  
Burgess Hill  
GB-West Sussex RH15 9TN  
Telephone +44 1444 236 000  
sales.euk@eao.com